

Project Documentation | Micro Radar Altimeter Data Sheet

Project Number:

SMS Project Number:

Project Title:

Micro Radar Altimeter

Keyword(s):

Micro Radar Altimeter Data Sheet

Date:

November 27, 2018

Document:

Micro_Radar_Altimeter_Data_Sheet.doc

CONFIDENTIAL AND PROPRIETARY

The information contained in this document may be subject to change without notice.

The information contained in this document shall remain the sole exclusive property of s.m.s smart microwave sensors GmbH.

1 User Safety Warning Information

Read the instructions carefully before you start to work.

Installation

Please observe the following advices when installing and connecting the sensors:

- Only use provided or approved equipment for installation. Use stainless screws with metric thread M3x8. Screw length must be adapted if the customer uses own brackets.
- Only skilled and instructed persons shall install and connect the devices. Proper experience in working with mains voltage, electrical and electronic devices is required.
- **Don't connect the devices directly to mains voltage, instead** use the voltage given in the manual.
- **Don't wire any connections while power is applied to** the device.
- Ground the devices carefully to prevent electrical shock.
- All connectors are pin-coded and fit in only one position. Also note the arrows indicating the top side of the sensor.
- Only use fully functional equipment (ladders, aerial work platform, ...) **when working** above ground. Staff shall be capable of working at heights.
- Use caution when installing the devices on or around active roadways. Pay attention to moving traffic.
- Mount the devices carefully to prevent them from shifting or dropping.
- The devices must be mounted to a stiff and solid support. Vibration, oscillation or any kind of movement will reduce the sensor performance.
- Make sure that your installation methods are in accordance with local safety policy and procedures and company practices.

Technical service

Only use provided or approved equipment for operation.

Persons other than authorized and approved electrical technicians shall NOT attempt to connect this unit to a power supply, Traffic Management Interface Board and/or other controllers, as there is a risk of electrical shock by unsafe handling of the power source.

Do not attempt to service or repair this unit.

- No user-maintainable parts are contained within the device.
- To avoid electrical shock, do not remove or open the cover.
- Unauthorized opening will void all warranties.
- Smartmicro is not liable for any damages or harms caused by unauthorized attempts to open or repair the device.

Radiation

This product has been tested and found to comply with Part 15 Subpart C of the Federal Communications Commission (FCC) or the European RED directive, or other national rules, depending on the country where it may be in use.

CONFIDENTIAL AND PROPRIETARY

The information contained in this document may be subject to change without notice.

The information contained in this document shall remain the sole exclusive property of s.m.s smart microwave sensors GmbH.

Operation is subject to the following two conditions:

1. This device may not cause harmful interference, and
2. This device must accept any interference received, including interference that may cause undesired operation.

This device generates radio frequency energy.

There are strict limits on continuous emission power levels. These limits are designed to provide reasonable protection against harmful interference when the equipment is operated in a commercial environment.

- Human exposure to transmitted waves from this device is generally considered as safe.
- Nevertheless, it is considered good practice that humans are not subject to higher radiation levels than necessary.
- This device may interfere with other devices using the same frequency band.

Operation

Transmission of radio frequency waves starts after the sensor is powered up and stops when disconnecting it from power.

Using a JBOX or SRO does not influence sensor performance.

For testing purposes, the sensor may be laid on its face when it is powered up, given that the surface or connectors will not be damaged by doing so. Please note that this position is not intended for permanent use.

It is recommended that only one connection interface is used at a time.

Do not operate the device if the device itself or any cables are damaged.

The sensors may become hot during operation, so proper hand protection is recommended for maintenance work.

CONFIDENTIAL AND PROPRIETARY

The information contained in this document may be subject to change without notice.

The information contained in this document shall remain the sole exclusive property of s.m.s smart microwave sensors GmbH.

Airborne Radar

Six good reasons to choose the Micro Radar A

1

Smallest Size

The Micro Radar Altimeter is the smallest size altimeter available today – 11 x 9.9 x 2.84cm. With just 310cm³ it outperforms all competitors.

2

Lowest Weight

Lowest weight radar altimeter on the market. Only 350g in standard housing. Sensational 160g for fully integrated version.

3

Lowest Power

Consuming just 3.7W from 7-32V DC it represents the lowest power altimeter device on the market.

4

Unbreakable Design

Derived from automotive design, the Micro Radar Altimeter is extremely robust, works in -40 to +85°C temperatures and withstands highest shock and vibration levels.

5

One Single Unit

Competitors need two models to cover 0.5 to 100m and 5m to max. height. The Micro Radar Altimeter does it all in one unit: 0.5 to 500m. Antenna System is integrated.

6

Fastest Update

While most altimeters need 100ms for one measurement, the Micro Radar Altimeter takes just 17ms for one cycle – ideal for terrain mapping.

2.1 Sensor Photographs

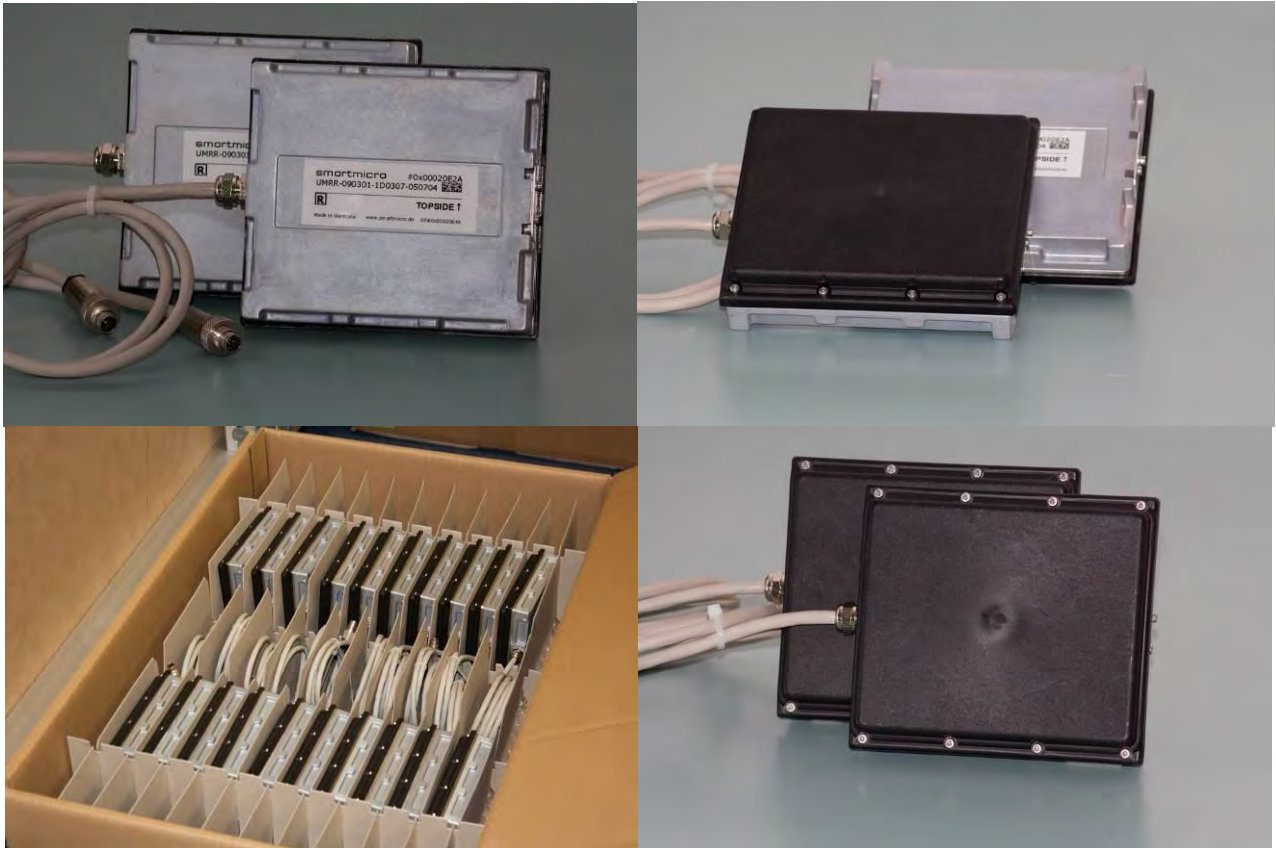

Figure 1: Photographs of Altimeter Sensor in Standard Housing.

CONFIDENTIAL AND PROPRIETARY

The information contained in this document may be subject to change without notice.

The information contained in this document shall remain the sole exclusive property of s.m.s smart microwave sensors GmbH.

2.2 General Performance Data

Parameter	Value	Unit
Sensor Performance		
Minimum Height	0.5 ¹	m
Maximum Height	500 ²	m
Supported Pitch and Roll angles	-20 ... +20 ³	degrees
Maximum vertical speed	50	m/s
Maximum forward speed	75	m/s
Height Accuracy	3% or 0.5m (maximum of)	
Update time	<= 17	ms
Start Up Time	< 1 (lower accuracy altitude available) < 5 (altitude result in spec.)	s
Environmental		
Ambient Temperature	-40 ... +85	degree C
Shock	100	g _{rms}
Vibration	14	g _{rms}
IP	67	
Pressure / Transport altitude	0...10.000	m
Mechanical		
Weight	350 ⁴ (incl. 0.5m cable and connector)	g
Dimensions	See 2.6	
Model No.	0Ax70x-22070x-05070x⁵ (standard) 0Ax70x-22070x-050A0x⁵ (light)	
DSP Board Identification	0Ax70x-22070x ⁵	
Housing Identification	05070x ⁵ (standard) or 050A0x ⁵ (light)	
General		
Power Supply	7 ... 32 ⁵ 3.7	V DC W
Frequency Band	24.0 ... 24.25	GHz
Bandwidth	< 200	MHz
Max. Transmit Power (EIRP)	17	dBm
Interfaces	CAN V2.0b (passive), RS485 ⁶	
Connector	8 Pin plug Binder Series 712 on 0.5m cable	CAN, RS485, Power

¹ Below minimum height, presence detection is available.

² Please note that the Radar system – like any other sensor system – although being well optimized and providing excellent performance, will not achieve a 100% detection probability and will not achieve a false alarm rate equal to zero.

³ Combined Pitch + Roll angle shall not exceed given value. If exceeded, max. altitude and accuracy will be reduced.

⁴ A lightweight variant is available at 160g weight, see section 2.3

⁵ measured at connector; min. voltage slew rate 500V/s or max. voltage rise time 15ms; supply source impedance 0.5Ohms.

⁶ It is recommended to use an external surge protection for power, CAN, RS485 and other interface ports.

CONFIDENTIAL AND PROPRIETARY

The information contained in this document may be subject to change without notice.

The information contained in this document shall remain the sole exclusive property of s.m.s smart microwave sensors GmbH.

2.3 Sensor Description and Hardware ID

Every UMRR sensor housing is tagged with a type sticker containing the product description and the serial number. It also contains a mark which side of the sensor is top. For the Micro Radar Altimeter, the TOPSIDE mark should be disregarded. Instead, the antenna and radome should be facing down, towards the earth.

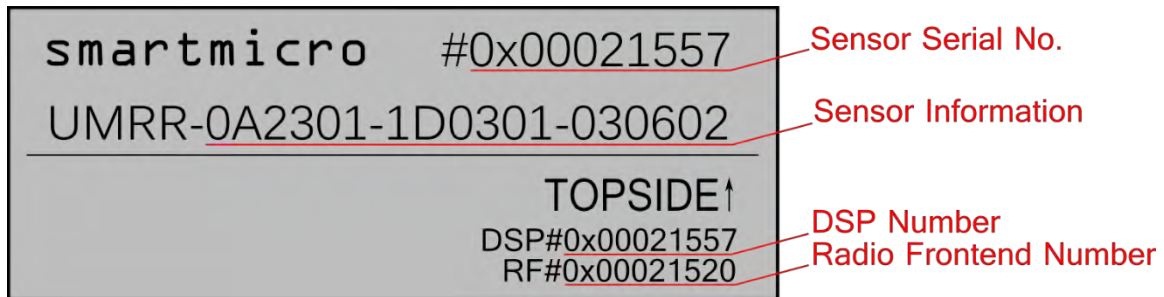

Figure 2: Type sticker example

The individual sensors are referred to as **UMRR-xyyyzz-aabbcc-ddeeff**

- xx** (DSP Board Generation xx)
- yy** (DSP Board Derivative/Version yy)
- zz** (DSP Board Revision zz)

- aa** (RF Board (Antenna) aa)
- bb** (RF Board Derivative/Version bb)
- cc** (RF Board Revision cc)

- dd** (Housing type dd)
- ee** (Housing Version ee)
- ff** (Housing Revision ff)

UMRR means Universal Medium Range Radar platform developed by Smartmicro.

The number in the top right corner is the unique serial number of the sensor. In addition to that the used DSP board and the RF board got their own unique serial numbers.

2.4 Light Weight Option

The light weight option is offered for weight optimized applications. This variant is **particularly suited for integration into the customer's enclosure**. If weight is very crucial, the altimeter even can be operated without a radome of its own but inside the customer's enclosure. The following deviations from section 2.2 apply.

CONFIDENTIAL AND PROPRIETARY

The information contained in this document may be subject to change without notice.

The information contained in this document shall remain the sole exclusive property of s.m.s smart microwave sensors GmbH.

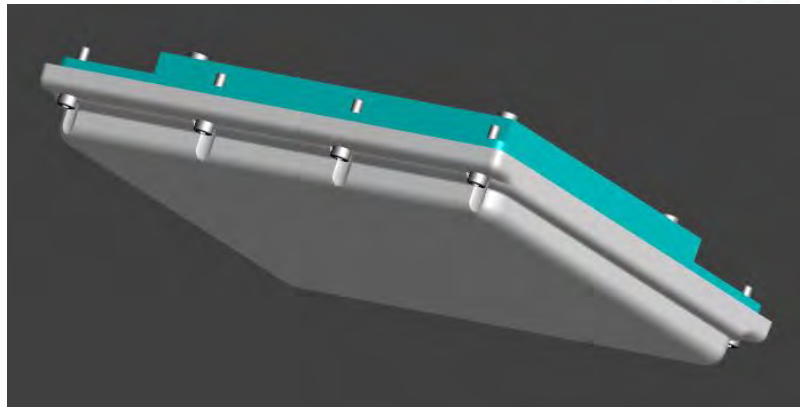

Figure 3: Light weight (integrated) model option including radome.

Parameter	Value	Unit
IP	40 (antenna part IP 67)	
Weight	160 fully integrated (customer radome) 235 integrated (including radome)	g
Dimensions	110 x 99 x 26 (without connector)	mm
Housing Identification	050A0x	
Model Number	UMRR-0Ax70x-22070x-050A0x	

2.5 Application Characteristics

2.5.1 Pitch and Roll

Up to 20 degree pitch and 20 degree roll are supported. The beam shape is circular, the sum of pitch plus roll must not exceed 20 degree in any direction.

2.5.2 Start-up time

After power up or reset, the altitude readings are within specified performance within 5 seconds.

2.5.3 On-board diagnostics (BIT)

The UMRR sensor cyclically reports a status message providing the following information (Continuous BIT)

- Sensor run time
- Sensor cycle time
- Sensor mode
- Hardware failure status bit
- Height output reliable bit

Initiated BIT is available. Sensor will send BIT results when it receives a command to do so.

CONFIDENTIAL AND PROPRIETARY

The information contained in this document may be subject to change without notice.

The information contained in this document shall remain the sole exclusive property of s.m.s smart microwave sensors GmbH.

2.6 Sensor Dimensions (Standard Model)

All values given in mm.

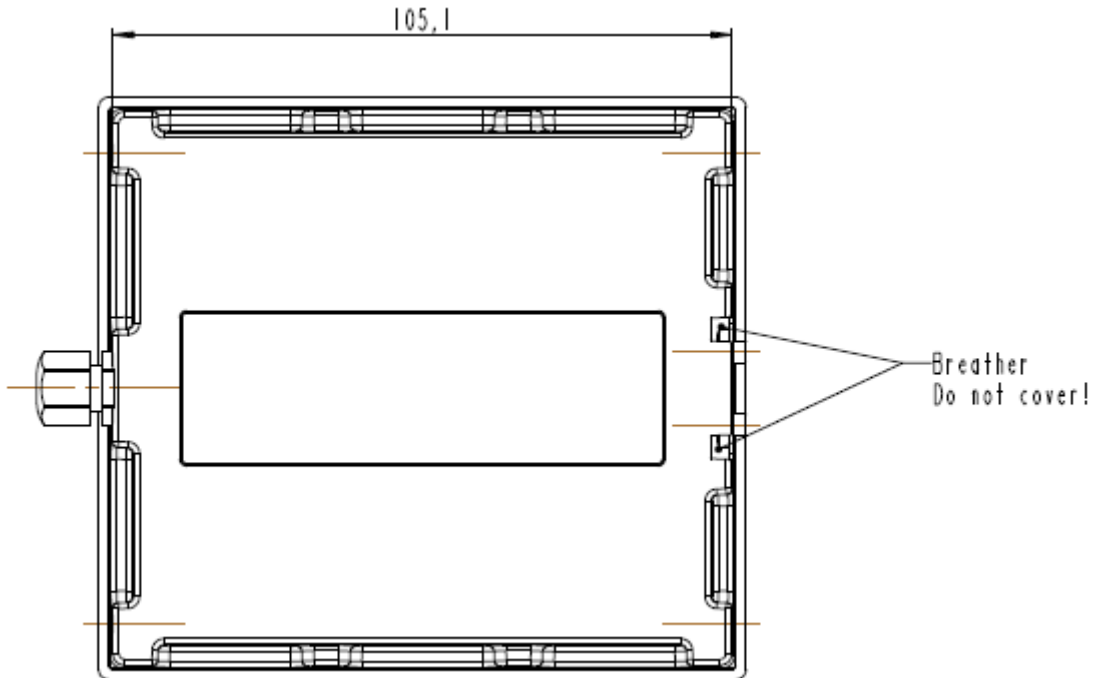

Figure 4: Sensor Rear Side.

CONFIDENTIAL AND PROPRIETARY

The information contained in this document may be subject to change without notice.

The information contained in this document shall remain the sole exclusive property of s.m.s smart microwave sensors GmbH.

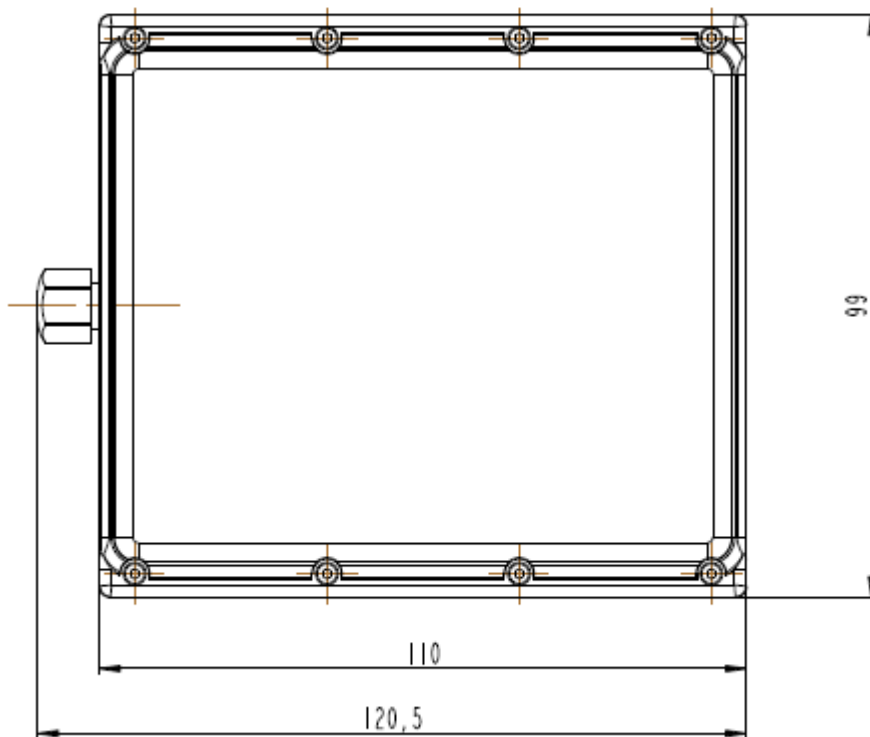
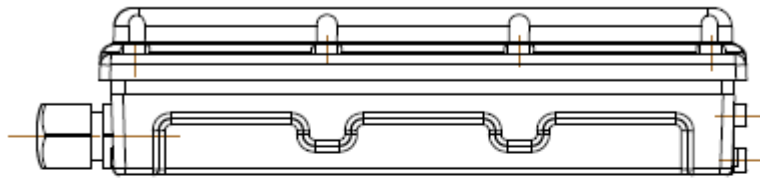

Figure 5: Sensor Front and Top Side.

CONFIDENTIAL AND PROPRIETARY

The information contained in this document may be subject to change without notice.

The information contained in this document shall remain the sole exclusive property of s.m.s smart microwave sensors GmbH.

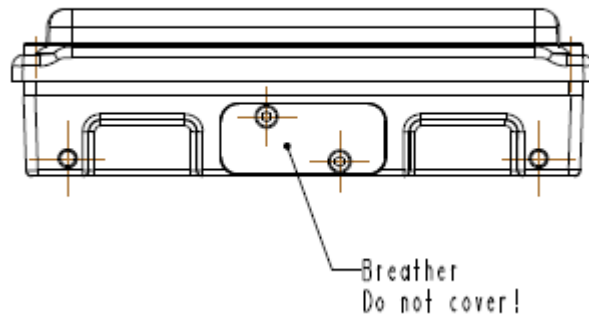

Figure 6: Sensor Left Side.

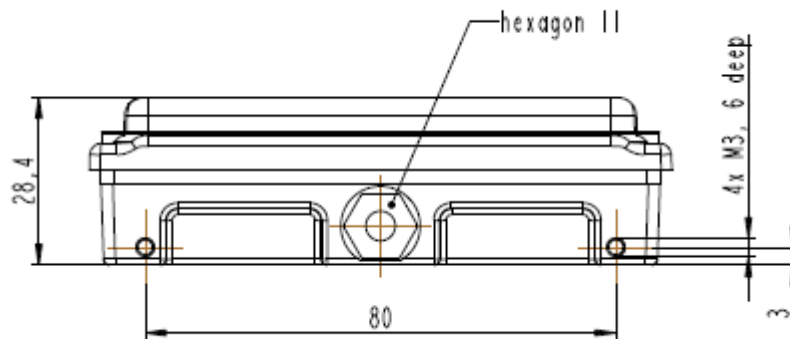

Figure 7: Sensor Right Side.

CONFIDENTIAL AND PROPRIETARY

The information contained in this document may be subject to change without notice.

The information contained in this document shall remain the sole exclusive property of s.m.s smart microwave sensors GmbH.

2.7 Cable and connector

2.7.1 Sensor connector

The used sensor connector is an 8-pin male (plug) circular connector (waterproof IP67, series 712, manufacturer Binder GmbH, Germany). A female counterpart (socket) has to be used to connect to the sensor. The pin numbering of the female connector is shown in Figure 8, the pin out of the connector is shown in Table 1.

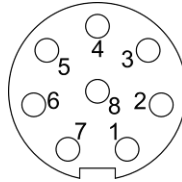

Figure 8: View on solder cup side of socket (rear view of female counterpart to be connected to sensor)

Pin	Function	Wire color
1	RS485 L	Pink = RS_485_L
2	Ground	Blue = GND
3	RS485 H	Grey = RS_485_H
4	CAN_L	Yellow = CAN_L
5	CAN_H	Green = CAN_H
6	not connected	Brown = n.c.
7	+7V...+32V	Red = Vcc (+7V...+32V)
8	not connected	White = n.c.

Table 1: Sensor connector pin out Model UMRR-0Axxxx, UMRR-0Bxxxx

Please note that in the standard configuration the sensor has no 120Ohms resistor on board (CAN bus termination between CAN_L and CAN_H)). The resistor is nevertheless possible at either end of a CAN bus and is in most cases integrated in the cable delivered along with the sensor (cable manufactured by Smartmicro).

CONFIDENTIAL AND PROPRIETARY

The information contained in this document may be subject to change without notice.

The information contained in this document shall remain the sole exclusive property of s.m.s smart microwave sensors GmbH.

3 Important Legal Disclaimer Notice

All Product, Product specifications and data in this project documentation are subject to change without notice to improve reliability, function, design or otherwise.

The statements, technical information and recommendations contained herein are believed to be accurate as of the date hereof. Smartmicro disclaims any and all liability for any errors, inaccuracies or incompleteness contained in this datasheet or in any other disclosure relating to the Product.

To the extent permitted by applicable law, Smartmicro disclaims (i) any and all liability arising out of the application or use of the Product or the data contained herein, (ii) any and all liability of damages exceeding direct damages, including - without limitation – indirect, consequential or incidental damages, and (iii) any and all implied warranties, including warranties of suitability of the Product for a particular purpose.

Statements regarding the suitability of Products for certain types of applications are based on Smartmicro' knowledge of typical requirements that are often placed on Smartmicro' Products in generic/general applications. Such statements are, however, not binding statements about the suitability of Products for a particular/specific application. It is the customer/user's own responsibility to validate that the Product with the specifications described herein is suitable for use in its particular/specific application. Parameters and performance of the Products may due to particular/specific applications and due to particular/specific surroundings deviate from the statements made herein. Therefore, it is important that customer/user has thoroughly tested the Products and has understood the performance and the limitations of the Products before installing the Products for the final applications or before commercialization. Although Products are well optimized to be used for the intended applications stated herein, it must also be understood by the customer/user that the detection probability may not be 100 % and the false alarm rate may not be zero.

The information provided herein, relates only to the specific Product designated and may not be applicable when such Product is used in combination with other materials or in any process not defined herein. All operating parameters, including typical parameters, must be validated for each customer application by the customer/user's technical experts. Customers using or selling Smartmicro products not expressly indicated for use in such applications do so at their own risk.

This Product specification or data sheet does not expand or otherwise modify Smartmicro terms and conditions of purchase, including but not limited to the warranty expressed therein.

Except as expressly indicated in writing by Smartmicro, the Products are not designed for use in medical, life-saving, or life-sustaining applications or for any other application in which the failure of the Product could result in personal injury or death.

No license, express or implied, by estoppel or otherwise, to any intellectual property rights is granted by this document or by any conduct of Smartmicro Product names and markings noted herein may be trademarks of their respective owners.

Please note that the application of the Product may be subject to standards or other regulations that may vary from country to country. Smartmicro does not guarantee that the use of Products in the applications described herein will comply with such regulations in any country. It is the customer/user's responsibility to ensure that the use and incorporation of Products complies with the regulatory requirements of their markets.

If any provision of this Disclaimer is, or is found to be, void or unenforceable under applicable law, that will not affect the validity or enforceability of the other provisions of this Disclaimer.

CONFIDENTIAL AND PROPRIETARY

The information contained in this document may be subject to change without notice.

The information contained in this document shall remain the sole exclusive property of s.m.s smart microwave sensors GmbH.

4 Contact

Address:

smart microwave sensors GmbH
In den Waashainen 1
38108 Braunschweig
Germany

Phone / Fax numbers:

Phone: +49-531-39023-0
Fax: +49-531-39023-599

Web / Email address:

Web: www.smartmicro.de
Email: info@smartmicro.de

CONFIDENTIAL AND PROPRIETARY

The information contained in this document may be subject to change without notice.

The information contained in this document shall remain the sole exclusive property of s.m.s smart microwave sensors GmbH.